

---

**+SWISSON**

**XSP / XSR  
DMX Splitter &  
RDM Hub  
User Manual**

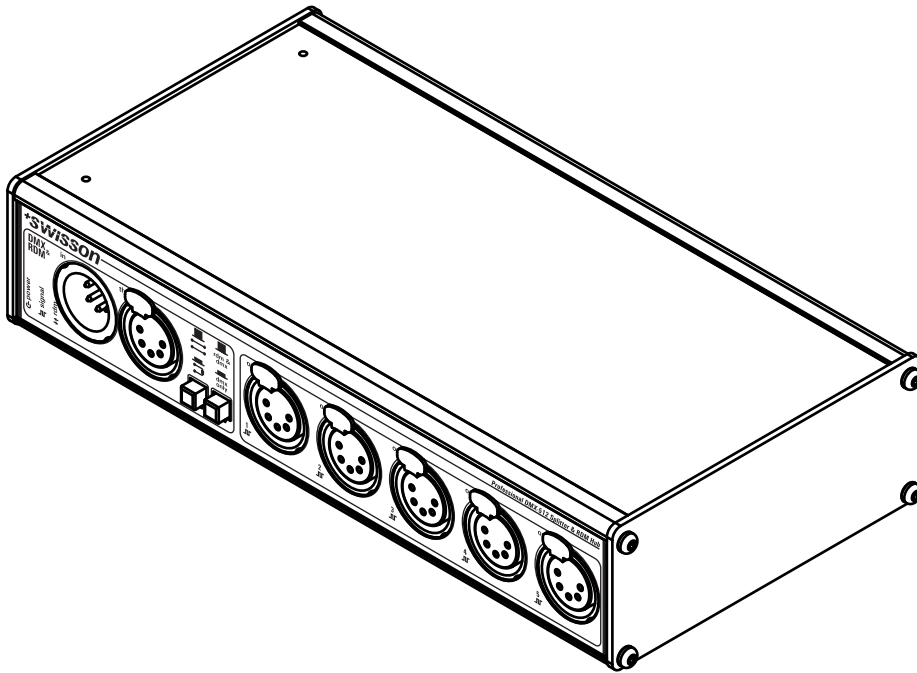

**USER MANUAL**

---

***+SWISSON***

English

**E****Revisions History**

Revision	Description	Date
1	First Draft	24.04.2012
1	Proofread	14.02.2014

# XSR and XSP

**E**

## DMX Splitter/Booster & RDM Hub

### Introduction

The XSR and XSP series of RDM hubs and DMX splitter/boosters from SWISSON can easily and economically be integrated into any lighting system where it is desirable to split and boost DMX and RDM signals.

While the XSP splits and boost only DMX signals, the XSR also detects RDM data and uses its bidirectional functionality to report back to the controller (Lighting Board).

All output ports on both XSP and XSR are optically isolated. A strong power supply allows for a reliable operation in a broad voltage range. A large program of XSR and XSP devices is available, consisting of different housings, different connector types and different numbers of input and output ports.

### Applications

- Concert Lighting
- Live Events
- Multimedia Shows
- Theater
- TV Sets
- Theme Parks
- Achitectoral Lighting
- Installations

### Typical Application

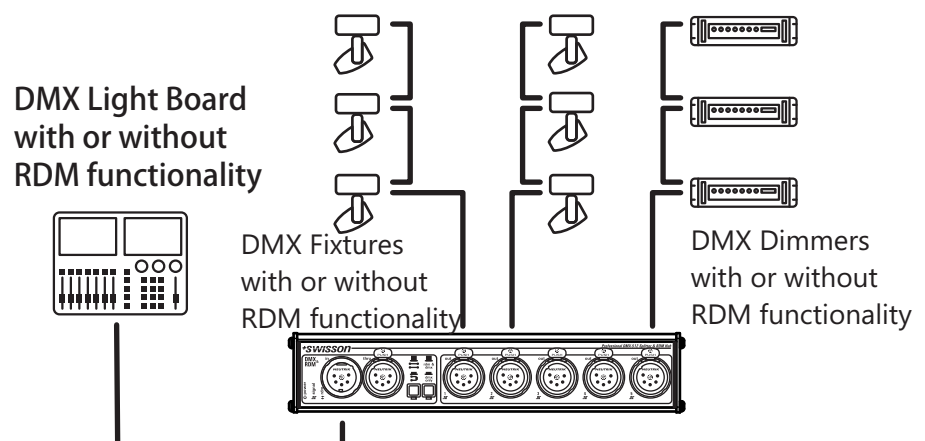

The XSR works within DMX / RDM environments, but can also operate mainly in pure DMX environments. The XSR is a good solution for those who expect to use RDM in future, because the XSR acts as a normal DMX splitter if there is no RDM data. The XSP works only within DMX environments.

### Unpacking

The DMX Splitter is packaged in a cardboard box. The following items are included:

- The device
- This user manual

# Safety Information **+SWISSON**

Consider the following notes mandatory when you set up, connect and use the XSP / XSR.

This product is approved for professional use only, it is not intended for household usage. Follow the safety instructions closely, when setting up, connecting and using the device. Read the manual before operating the device and pay attention to all the instructions or warnings given in this manual or printed on the product.

**E**

Use this device only in accordance with local laws and regulations.

## Safety Precautions

- Disconnect the device from the AC power supply before removing any cover or part, including fuse, even when not in use.
- Ensure the device is electrically connected to ground (earth).
- Use only a source of AC power supply that complies with local building and electrical regulations and which has both overload and ground-fault (earth fault) protection.
- Connect the device to a AC power supply using the supplied power cable.
- Before using the device, check that the power distribution equipment and cables are in perfect condition and rated for the current required of all connected devices.
- Isolate the device from power supply immediately if the power cable or power plug are in any way damaged, defective or wet, or if they show signs of overheating.
- Do not expose the device to rain or moisture.
- Do not operate the device if any cover or component is missing, damaged or deformed.
- Refer any service operation not described in this manual to SWISSON AG.
- Provide unrestricted airflow around the device.
- Do not operate the device where the ambient temperature exceed 55°C (131°F)
- Do not modify the device in any way other than described in this manual or install other than genuine SWISSON parts.
- Do not attempt to bypass the fuse. Replace defective fuse with one of the specified type and rating only.
- When suspending the device, ensure that the supporting structure and all hardware used is capable to withstand at least 10 times the weight of all devices suspended together.
- Install as described in this manual, a secondary attachment such as a safety cable that has been approved by an official body such as, e.g. TÜV (German Technical Monitoring Association) as a safety attachment for the total weight it secures. The safety cable must comply with EN 60598-2-17 Section 17.6.6 and be capable of bearing a static suspended load representing 10 times the actual weight of the device.
- Make sure that all external covers and rigging hardware are securely fastened.
- Provide clearance underneath the work area and a stable platform whenever installing, servicing or moving an overhead device.
- Do not use the device in areas where it is exposed to direct sunlight.
- Do not use the device in areas that are considered to be 'highly inflammable'.

## Benefits of using a XSP/XSR Splitter / Booster

### **E** Boost

On installations with excessively long cable runs the DMX and/or RDM signal can be compromised or significantly weakened by the distance.

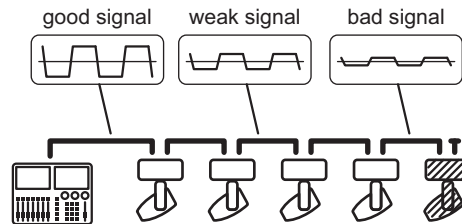

The XSP/XSR boosts the signals thus eliminating signal interference encountered in such situations.

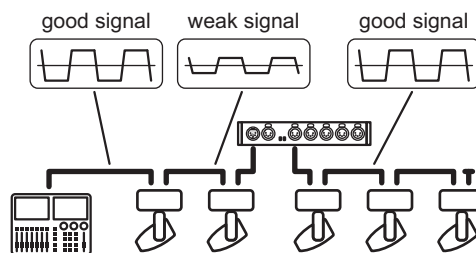

### Regeneration

In harsh environments DMX and RDM signals can be disturbed or corrupted.

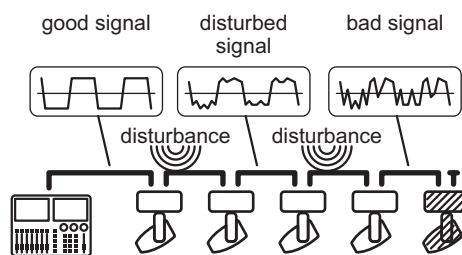

The XSP/XSR cleans and regenerates the signals.

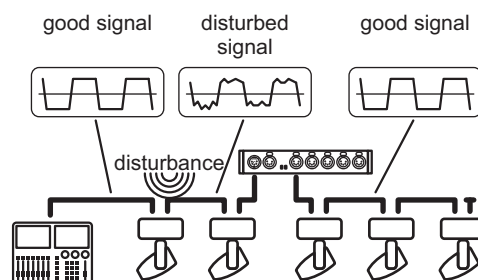

## Splitting

A simple split of signal lines is not allowed. The bidirectional operation of RDM is even more sensitive to the split than DMX.

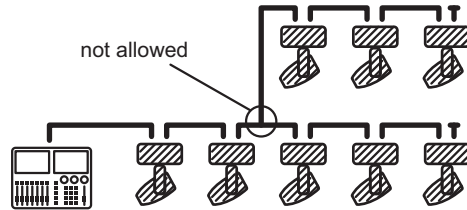

**E**

A split of the signal lines is possible with the XSR / XSP by using different output ports.

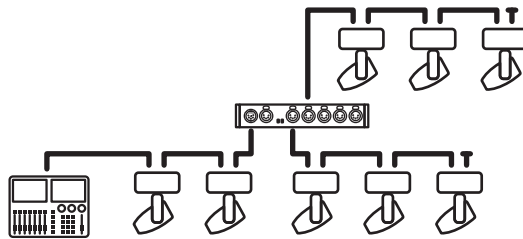

## Reduction of Reflection Problems

Signal reflection is a common problem in large DMX installations or on long signal lines. The bidirectional operation of RDM is more sensitive to reflections than DMX.

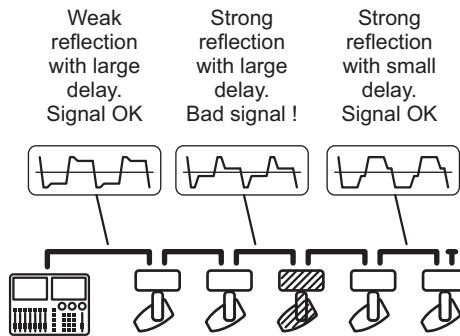

The XSP/XSR splits the line into smaller segments with a regenerated signal, which reduces the delay of the reflection at each segment.

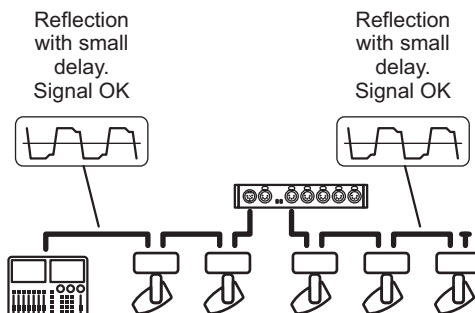

## Protection

In case of an over voltage on the DMX and RDM line(s), all devices on that line can be damaged.

**E**

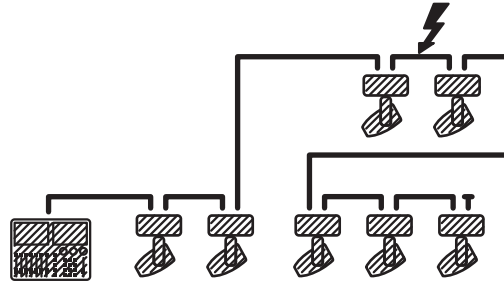

The XSP/XSR separates the line into multiple segments. The over voltage is restricted to the concerned segment. The XSP/XSR itself is well protected against transient over voltage and the optical isolation of each port prevents a damage to other ports and segments in case of a permanent over voltage.

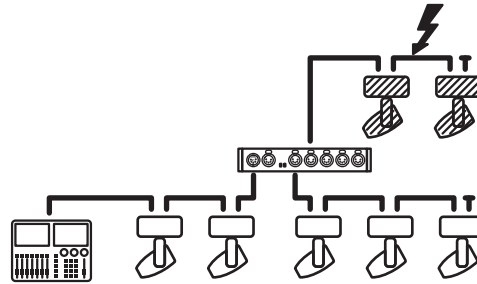

## XSP Block Diagram

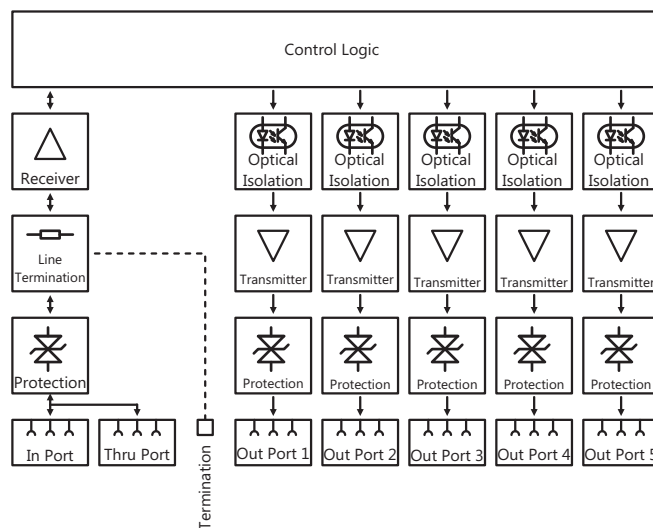



## XSR Block Diagram

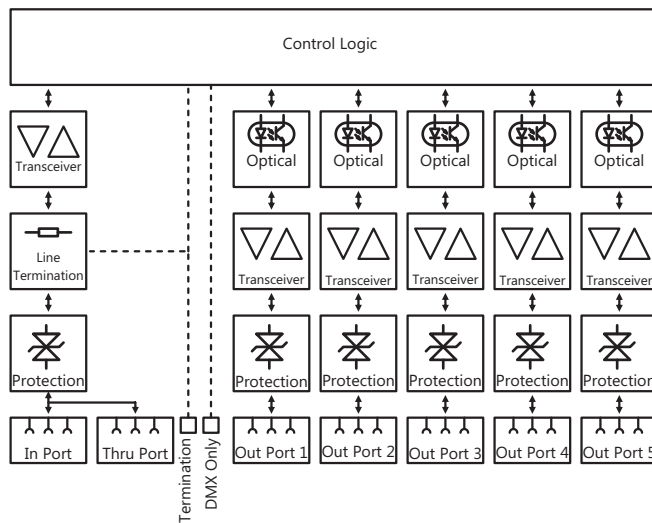

E

## Mains Connection

Two different mains connections are available:

The US versions are delivered by SWISSON with an "Edison Plug" (NEMA-5-15). These models carry a "-US" suffix at the end.

The international versions are supplied plugless. *SWISSON distributors or dealers may deliver the devices with a country specific plug.*

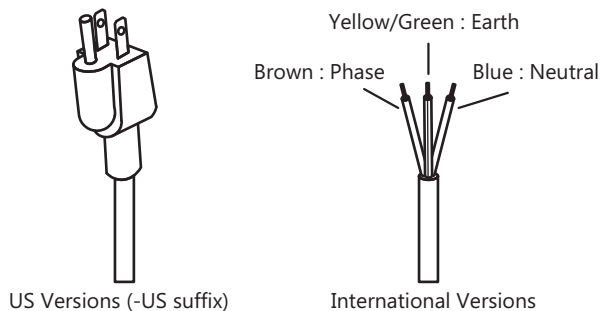

US Versions (-US suffix)

International Versions

	Wire (US System)	Wire (EU System)	Symbol
Live	black	brown	L
Neutral	white	blue	N
Ground (Earth)	green	yellow/green	⏏ or ⏚



**Consult a qualified electrician if you have any doubts about proper installation.**

**The socket where the device is plugged in must be close to the device and easy to access.**

## Input Section of XSP Versions



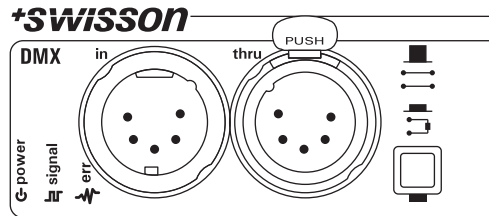

The Input section of versions with XLR connectors

**E**



The Input section of the versions with terminals:  
The "input" and "thru" terminals are located on the back of the device.



-  The Power LED indicates if the device is powered and if the power supply unit of the XSP is working.
-  A green LED indicates if a signal is available at the Input port.
-  A red LED indicates if the received signal is faulty.
-  The XSP has a built-in line termination. This can be activated by pressing the termination button. A LED indicates if the termination is activated.

## Input Section XSR Versions

The Input section of the XSR versions with XLR connectors

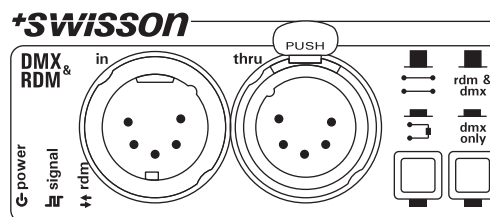

The Input section of the XSR versions with terminals:  
The "input" and "thru" terminals are located on the back of the device.



**Power**

The Power LED indicates if the device powered and if the power supply unit of the XSR is working.

**Signal**

A multicolor LED indicates if a signal is available at the Input port. The LED has 2 different states:

- Green: Signal is present and Ok
- Red: No signal is present or signal is present but faulty

**RDM**

The RDM LED indicates if RDM data packets are preset. In a pure DMX environment this LED remains in OFF state.



The XSR has a built-in line termination. This can be activated by pressing the termination button. A LED indicates if the termination is activated.

**DMX only**

The "DMX only" function of the XSR allows removal of all RDM data from the Output ports. A LED indicates if the "DMX only" function is activated.

## RDM Identify

Blinking of all Output LEDs: The RMD Identify is activated.

## Errors

Blinking of "DMX only" LED: Error UID not valid. RDM operation is not possible. DMX operation only.

Blinking of all LEDs (except power and termination LED): Fatal error

## Input and Thru Port

The THRU port is hardwired with the INPUT port and allows to daisy-chain the devices, even when the XSR is not powered. On all XSP and XSR models with a 5-Pin XLR connector the pin 4 and 5 are also looped through to the THRU port. On all other models pin 4 & 5 are not available.

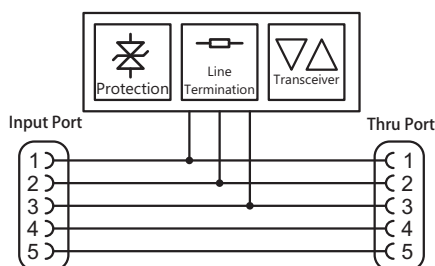

## Line Termination

All XSP and XSR splitters have a built-in line termination. The termination is activated by pressing the termination button. On terminal and Installation versions the button can only be accessed using a tool (such as a paper clip).

**E**

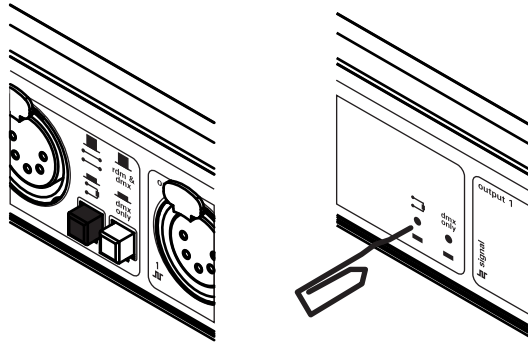

## DMX Only (only on XSR models)

The "DMX only" function removes all non DMX data before sending the data to the Output ports. RDM data will be removed too. This can be helpful when DMX devices are not compatible and do not check the data they receive as valid DMX signals. The "DMX only" function is activated by pressing the "DMX only" button. On terminal and Installation versions, the button is only accessible with a tool.

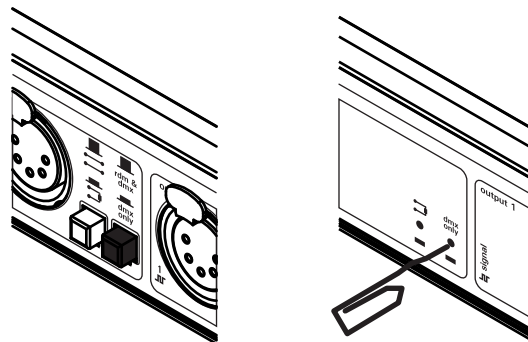

## Output Ports

The output section of versions with XLR connectors:

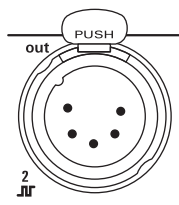

The OUTPUT section of versions with terminals:

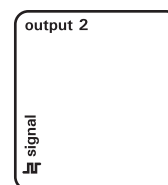

The OUTPUT terminals are located on the back of the devices.

Each Output port is individually optically isolated, meaning that it is totally isolated from the other Output ports and the Input selection. The Pins 4&5 on models with 5-Pin XLR connectors are not connected.

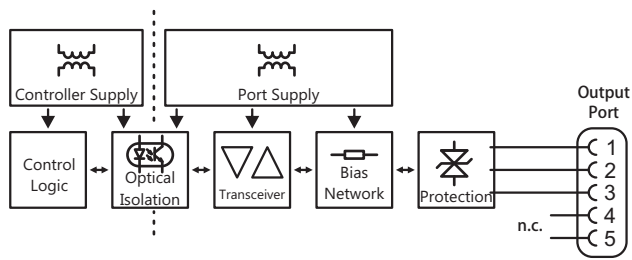

**E**

signal  
IF

On the XSR, the indicator LED of the OUTPUT ports indicates if a valid signal is transmitted. It works bidirectionally:

When sending DMX or RDM packets and when receiving RDM responses.

This LED is not available on XSP models.

## XSP / XSR Box Models

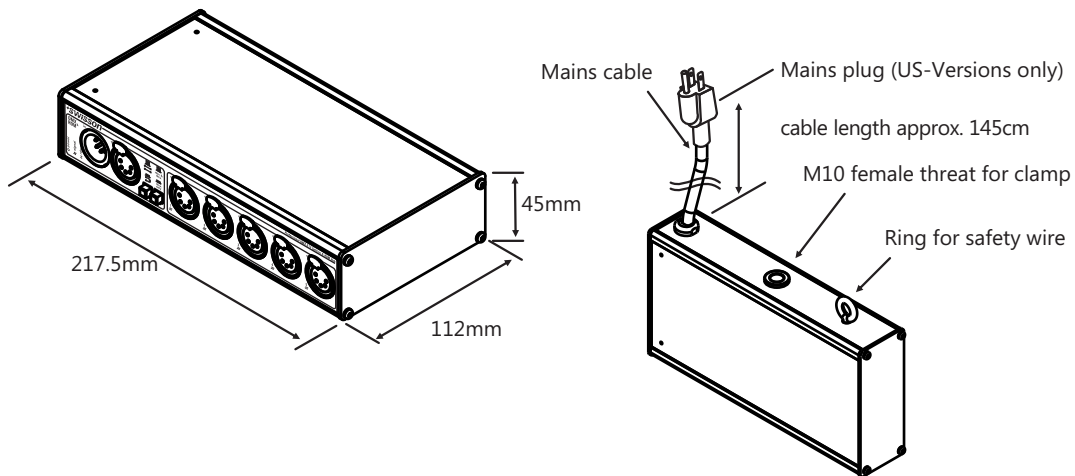

The M10 screw which enters the XSP/XSR should not exceed a maximum length of 20mm.

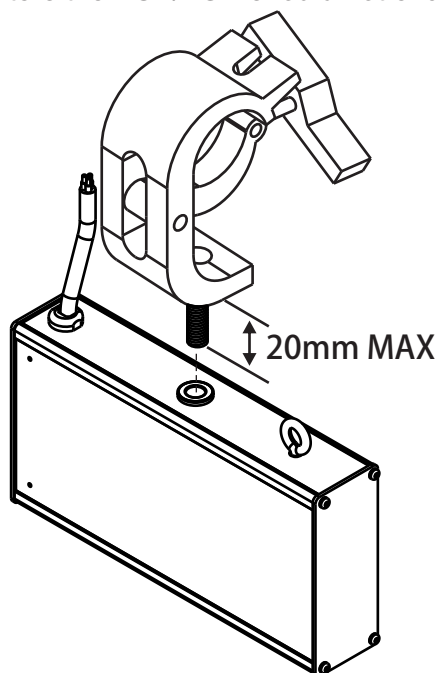

Clamp is not included with the XSP/XSR.

## Single Rack Models

E

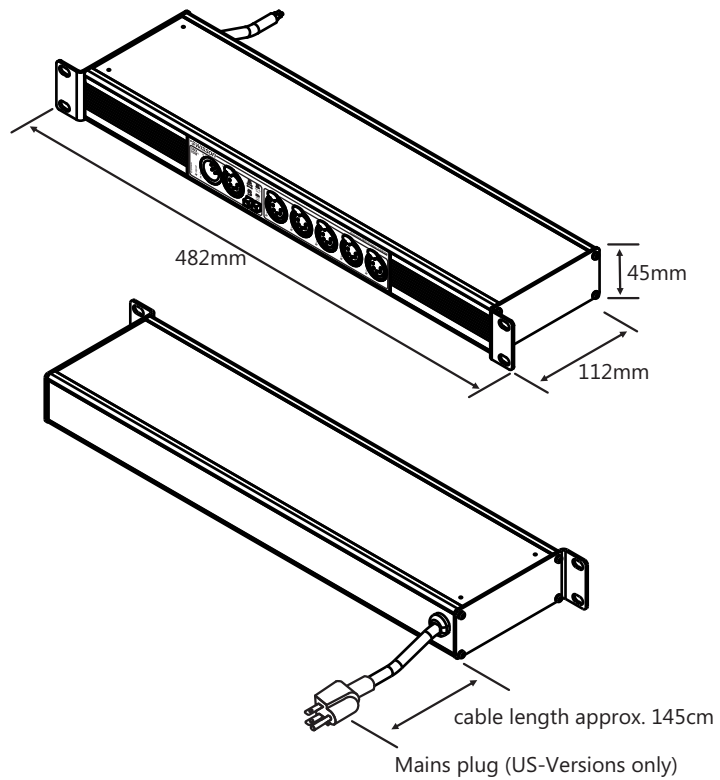

## Double Rack Models

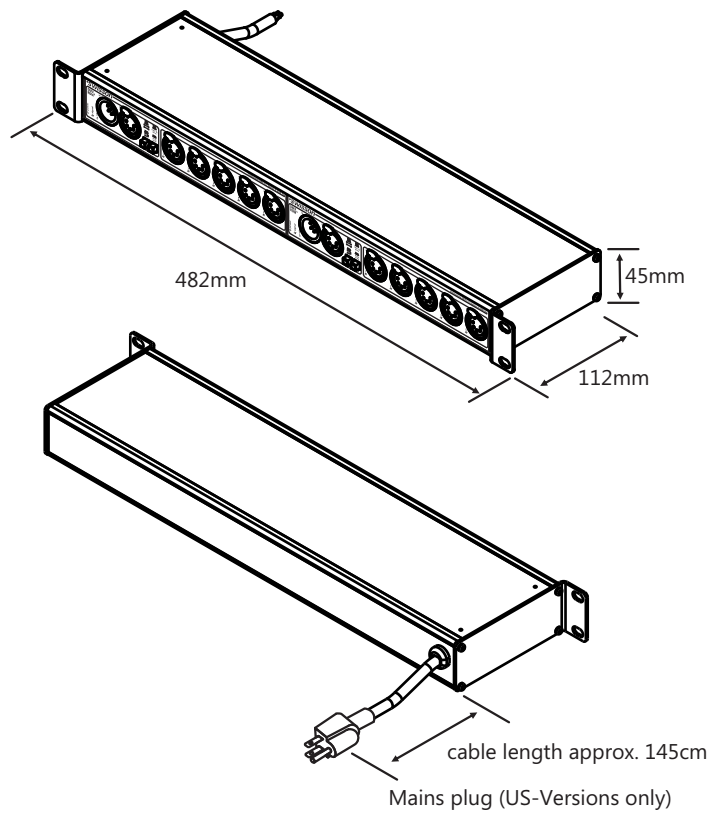

## Single Rack Terminal Models

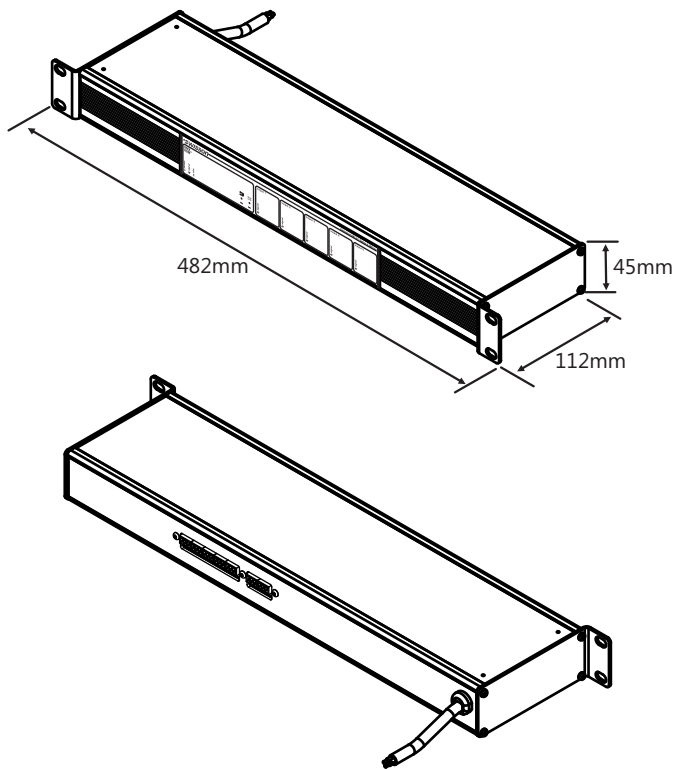

## Double Rack Terminal Models

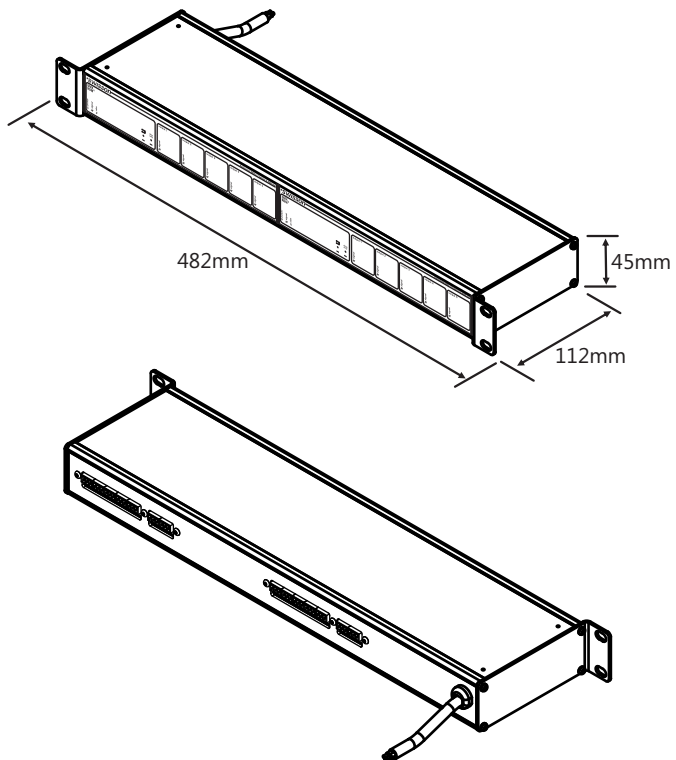

## Terminal Models

The terminal models of the XSP/XSR series come with pluggable terminal blocks. The terminal blocks are located on the back of the devices.

**E**

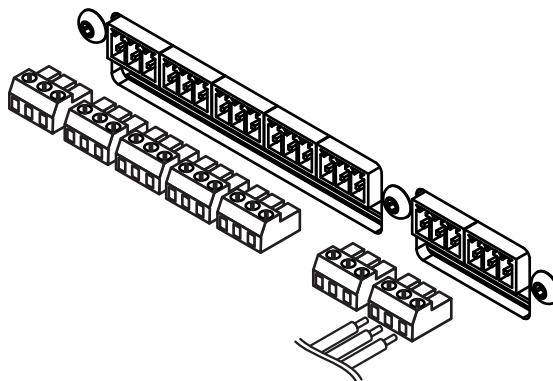

XSP/XSR terminal models are shipped with the terminal blocks. They can accept wires up to AWG 17 (~1mm<sup>2</sup>)

## Installation Models

The XSP/XSR installation model is manufactured to be installed by certified professionals. This version has no plugs. The connections are all located inside the device.

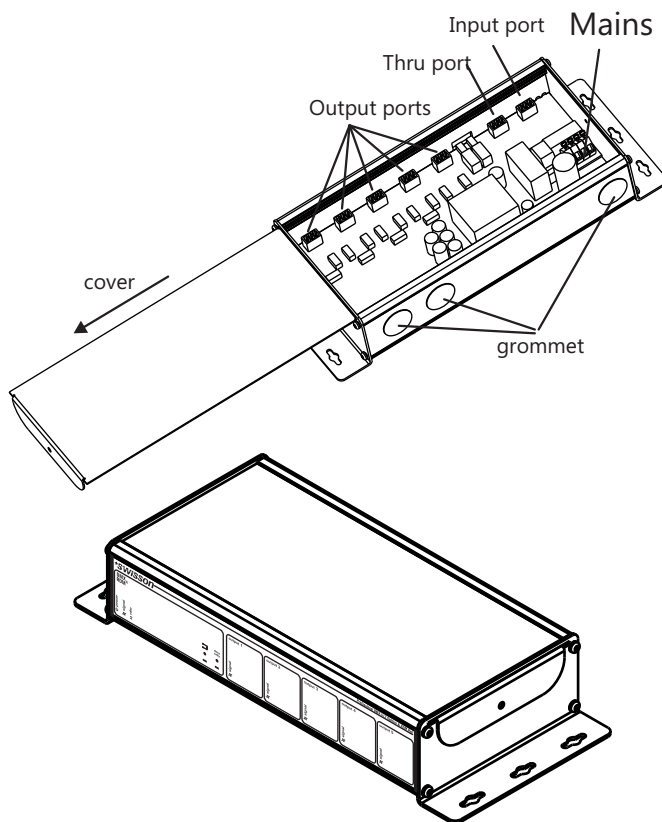



## XSP Standard Program

- 
- 10 11 63 XSP-3B
  - 11 11 63 XSP-3B-US (with NEMA 5-15)

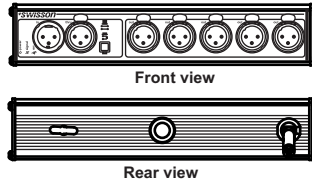

- 
- 10 11 74 XSP-3R
  - 11 11 74 XSP-3R-US (with NEMA 5-15)

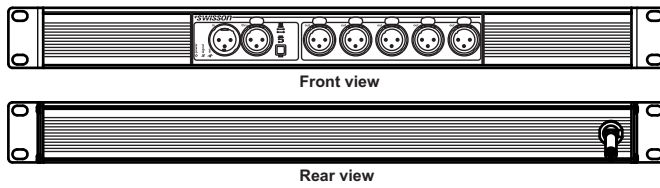

- 
- 10 11 85 XSP-3R-3R
  - 11 11 85 XSP-3R-3R-US (with NEMA 5-15)

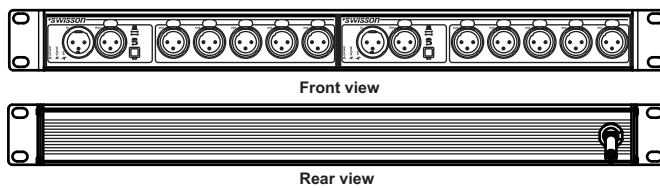

- 
- 10 11 62 XSP-5B
  - 11 11 62 XSP-5B-US (with NEMA 5-15)

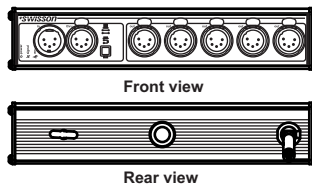

- 
- 10 11 72 XSP-5R
  - 11 11 72 XSP-5R-US (with NEMA 5-15)

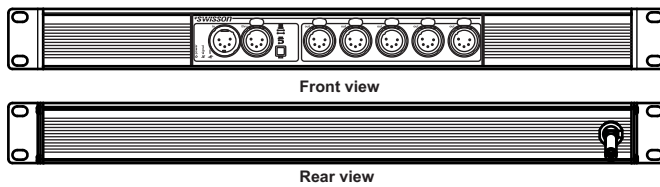

- 
- 10 11 82 XSP-5R-5R
  - 11 11 82 XSP-5R-5R-US (with NEMA 5-15)

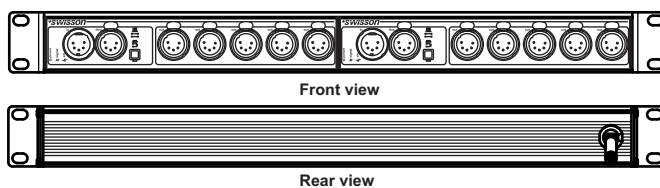

E

**E**

- 
- 10 11 60 XSP-5B5
  - 11 11 60 XSP-5B5-US (with NEMA 5-15)

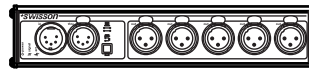

Front view

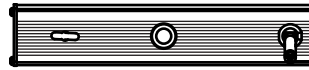

Rear view

- 
- 10 11 70 XSP-5R5
  - 11 11 70 XSP-5R5-US (with NEMA 5-15)



Front view



Rear view

- 
- 10 11 80 XSP-5R5-5R5
  - 11 11 80 XSP-5R5-5R5-US (with NEMA 5-15)



Front view



Rear view

- 
- 10 11 87 XSP-5R2-5R2
  - 11 11 87 XSP-5R2-5R2-US (with NEMA 5-15)



Front view

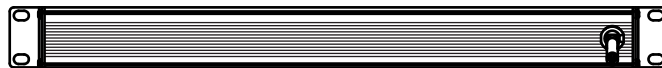

Rear view

- 
- 10 11 84 XSP-5R-5R5
  - 11 11 84 XSP-5R-5R5-US (with NEMA 5-15)



Front view



Rear view

- 
- 10 11 86 XSP-5R-3R
  - 11 11 86 XSP-5R-3R-US (with NEMA 5-15)



Front view



Rear view

10 11 50 XSP-TR5  
 11 11 50 XSP-TR5-US (with NEMA 5-15)

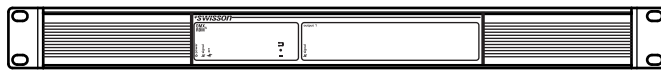

Front view

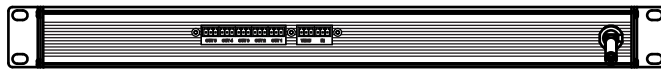

Rear view

10 11 51 XSP-TR5-TR5  
 11 11 51 XSP-TR5-TR5-US (with NEMA 5-15)

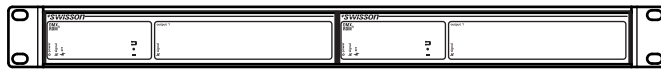

Front view

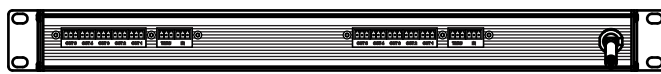

Rear view

10 11 98 XSP-IB5-W

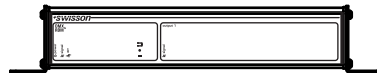

Front view

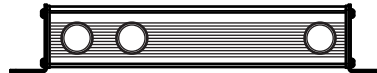

Rear view

## XSR Standard Program

10 12 10 XSR-3B  
 11 12 10 XSR-3B-US (with NEMA 5-15)



Front view



Rear view

10 12 20 XSR-3R  
 11 12 20 XSR-3R-US (with NEMA 5-15)

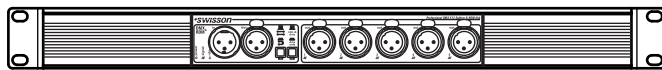

Front view



Rear view

10 12 30 XSR-3R-3R  
 11 12 30 XSR-3R-3R-US (with NEMA 5-15)



Front view

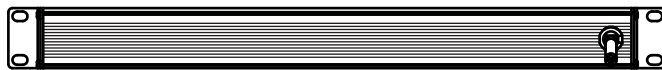

Rear view

E

**E**

- 
- 10 12 11 XSR-5B
  - 11 12 11 XSR-5B-US (with NEMA 5-15)

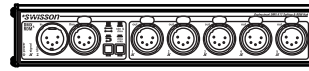

Front view

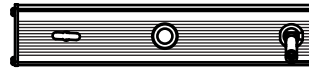

Rear view

- 
- 10 12 21 XSR-5R
  - 11 12 21 XSR-5R-US (with NEMA 5-15)



Front view

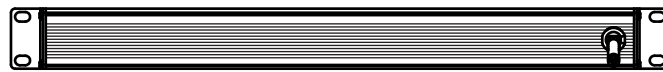

Rear view

- 
- 10 12 31 XSR-5R-5R
  - 11 12 31 XSR-5R-5R-US (with NEMA 5-15)



Front view



Rear view

- 
- 10 12 16 XSR-5B5
  - 11 12 16 XSR-5B5-US (with NEMA 5-15)



Front view

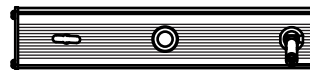

Rear view

- 
- 10 12 26 XSR-5R5
  - 11 12 26 XSR-5R5-US (with NEMA 5-15)



Front view



Rear view

- 
- 10 12 33 XSR-5R5-5R5
  - 11 12 33 XSR-5R5-5R5-US (with NEMA 5-15)



Front view

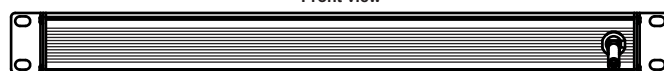

Rear view

10 12 35 XSR-5R2-5R2  
 11 12 35 XSR-5R2-5R2-US (with NEMA 5-15)



Front view

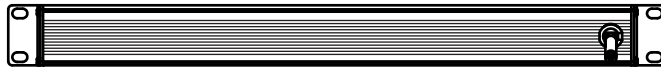

Rear view

10 12 34 XSR-5R-5R5  
 11 12 34 XSR-5R-5R5-US (with NEMA 5-15)



Front view

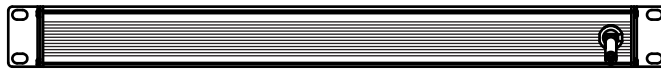

Rear view

10 12 32 XSR-5R-3R  
 11 12 32 XSR-5R-3R-US (with NEMA 5-15)



Front view

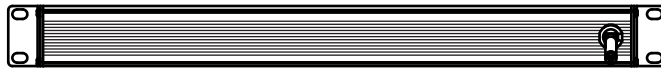

Rear view

10 12 50 XSR-TR5  
 11 12 50 XSR-TR5-US (with NEMA 5-15)



Front view

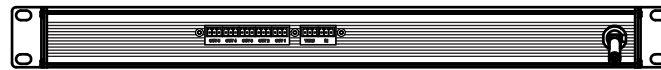

Rear view

10 12 51 XSR-TR5-TR5  
 11 12 51 XSR-TR5-TR5-US (with NEMA 5-15)



Front view

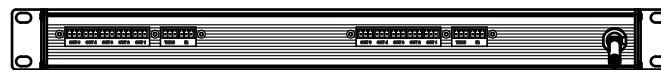

Rear view

10 12 51 XSR-IB5-W



Front view



Rear view

E

## Technical Data

Mains Voltage	100 - 240 [VAC]
<b>E</b> Main Frequency	50/60 [Hz]
Current Consumption Single Units	0.2 [A]
Current Consumption Double Units	0.4 [A]
Operating Temperature	0°F to 131°F (-17°C to 55°C)
Protocol Standard	ANSI E1.11 (DMX-512) ANSI E1.20 (RDM)
Safety Standards	EN60950-1 UL508
EMC emission	EN55103-1
EMC immunity	EN55103-2

No part of this documentation may be reproduced or transmitted in any form or by any means, electronically or mechanically, including photocopying and recording, without the prior written permission of SWISSON AG.

The information in this documentation is supplied without warranty of any kind, either directly or indirectly, and is subject to change without prior written notice. SWISSON AG, its employees or appointed representatives will not be held responsible for any damages to software, hardware, or data, arising as a direct or indirect result of operating and/or handling the product(s) mentioned herein.

Issued by

SWISSON AG  
Fabrikstrasse 21  
CH-3250 Lyss  
Switzerland

SWISSON of AMERICA Corp.  
2419 East Harbor Blvd. #34  
Ventura, CA 93001  
U.S.A.

e-mail: [welcome@swisson.com](mailto:welcome@swisson.com)